

DVTS R2-50 TUMBLER



Just what you have been looking for. A 50 lb. table top tumbler. This tumbler is compact and can tumble up to 50 lbs. at a time. Perfect for restaurants, delies, meat market display case products or as the main tumbler in a smaller meat market. LED timer - hours and minutes. Easy to remove lid. Easy to clean. Liquid filled vacuum gauge. Drain plug on tank. Easy to replace vacuum filter. Variable speed, 0 - 16 rpm. Direct drive. 115 volt.

DANIELS FOOD EQUIPMENT

DVTS R2-50 TUMBLER

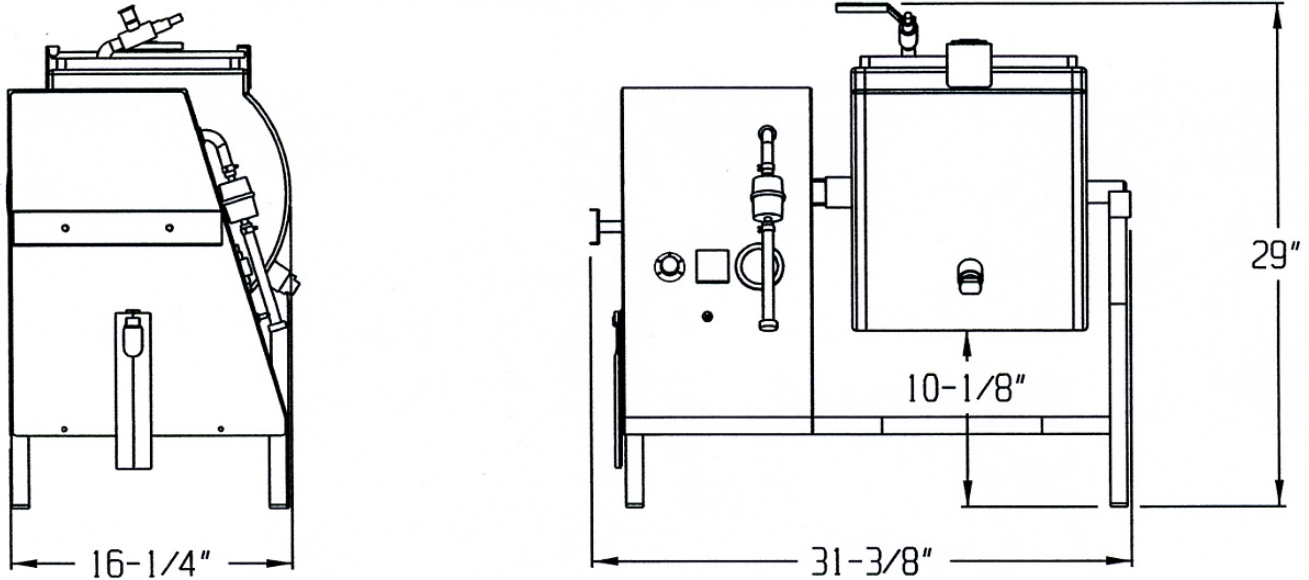

SPECIFICATIONS

TOTAL POWER INPUT:	15 AMP, 115 VOLT, 60 Hz CIRCUIT
TUMBLER DRIVE:	ELECTRONIC SPEED CONTROL INPUT 115 VOLT AC 50/60 Hz FUSED AT 3 AMPS.
TUMBLER DRIVE MOTOR:	120: 1 RATIO
VACUUM PUMP:	115 VOLT 3.5 AMPS, 60 Hz
TIMER:	DIGITAL-HOURS AND MINUTES
VACUUM GAUGE:	(RANGE) 0 TO 30 INCHES OF MERCURY
ELECTRONIC CONTROLS:	TUMBLER SPEED-ADJUSTABLE 0 TO 16 RPM, TIMER "START- STOP" VACUUM PUMP "STOP"- "START" TOGGLE SWITCH
MAXIMUM CAPACITY:	50-LBS.
MATERIAL:	300 SERIES STAINLESS STEEL TUMBLER, FRAME AND HOUSING
WEIGHT:	132-LBS. (SHIPPING WEIGHT) 100-LBS. (NET)

Distributed By:
Doug Care Equipment, Inc.
PO Box 1058
Springville, CA 93265
888-278-0377 doug@dougcare.com