

DVTS 30 TUMBLER



Just what you have been looking for, the lowest priced 30 Lb. tumbler on the market. Perfect for restaurants, delis, meat market display case products and even home use. LED timer - hours and minutes. Easy to remove tank - just lift it off. Easy to clean. Vacuum gauge. Clear lid. Single speed, 9 rpm. 30 Lb. capacity, 25 Lb. tumble capacity. 115 volt.

DANIELS FOOD EQUIPMENT

DVTS 30 VACUUM TUMBLER

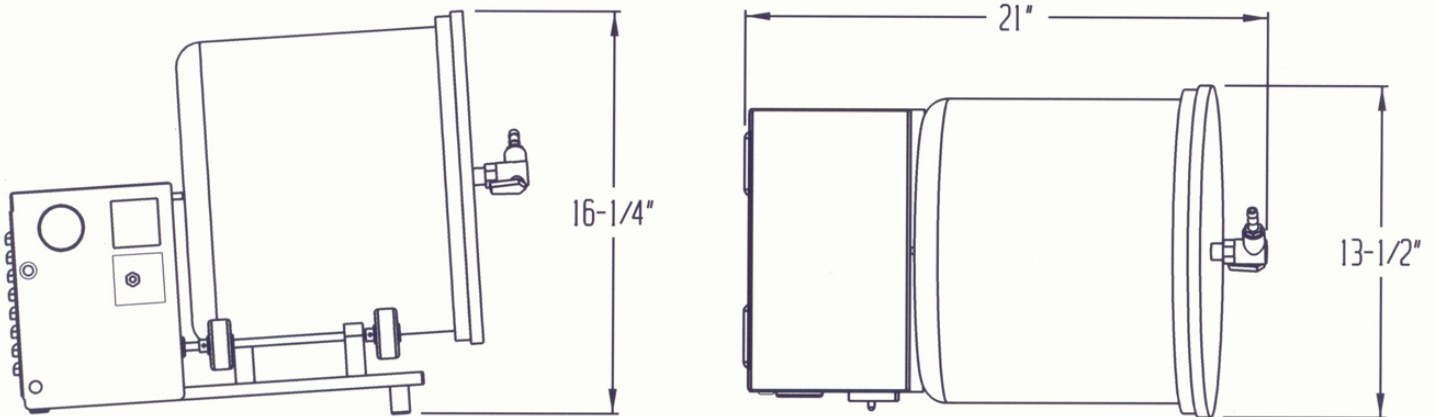

SPECIFICATIONS

POWER SUPPLY:	15 AMP, 120 VOLT, 60 Hz CIRCUIT
TUMBLER SPEED:	9 RPM
VACUUM PUMP:	0 – 22 (IN. HG.)
TIMER:	LED READ OUT IN HOURS AND MINUTES
FEATURES:	VACUUM GAUGE, TIMER, TUMBLE / VACUUM – TOGGLE SWITCH
CAPACITY:	30-LBS. MAXIMUM, 25 LBS. TUMBLE CAPACITY
WEIGHT:	29-LBS. (NET)

Distributed By:
Doug Care Equipment, Inc.
PO Box 1058
Springville CA 93265
888-278-0377 doug@dougcare.com