

DVTS 2000 AND 3000 TUMBLER

● Reliable Hydraulic Drive

● Hydraulic Dump

● Made in the USA



● Easy to Remove Lid

● Forward And Reverse Tumbling

● All Stainless Steel Construction

● Variable Speed Control (0-16 RPM)

If your looking for a quality tumbler that can handle the big loads you found it! The DVTS 2000 and 3000 tumbler Has variable speed control, 0 to 16 rpm. Safety rail. LED timer in hours and minutes. Foward and reverse tumbling. This tumbler has hydraulic tilt for easy unloading and cleaning, tilt it all the way back for easy loading. Easy to change vacuum filter. Liquid filled vacuum guage. Gain profits by tumbling, weight gain and tenderizing all in minutes.

DANIELS FOOD EQUIPMENT

DVTS 2000 AND 3000 TUMBLER

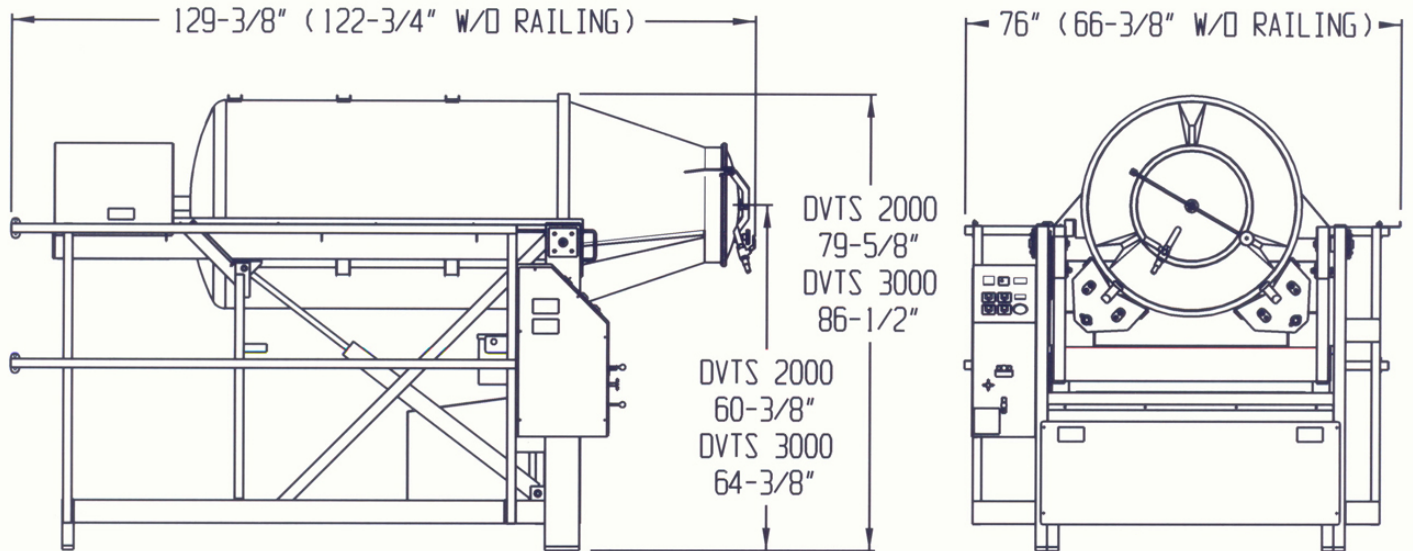

SPECIFICATIONS

| | |
|---------------------------------|--|
| MOTOR: | 15.4 Amps, 220 Volt, 3 Phase, 60 Cycle, 5 Hp |
| TUMBLER DRIVE: | Hydraulic Drive |
| VACUUM PUMP: | 208/230/460 Volt, 3 Phase, 1-1/2 Hp, Capacity 4.6 Cubic Feet Per Min @ 20" Hg |
| TUMBLER CONTROLS: | Variable Speed Control, 16 RPM Max, Forward And Reverse, Tumbler Lift And Lower, Tachometer, Hour meter, Vacuum Gauge, Timer: Minutes And Hours Up To 99 Hours |
| IDEAL TUMBLING CAPACITY: | (DVTS 2000; 2000 LBS.) (DVTS 3000; 3000 LBS.) |
| MAXIMUM CAPACITY: | (DVTS 2000; 2600 LBS.) (DVTS 3000; 3500 LBS.) |

Distributed By:
Doug Care Equipment, Inc.
PO Box 1058
Springville CA 93265
888-278-0377 doug@dougcare.com