



Minipack-torre S.p.A.

Via Provinciale, 54 - 24044 Dalmine (BG) - Italy
Tel. (035) 563525 – Fax (035) 564945
E-mail: info@minipack-torre.it
<http://www.minipack-torre.it>



I ISTRUZIONE PER L'INSTALLAZIONE, L'USO E LA MANUTENZIONE
GB INSTALLATION, OPERATION AND MAINTENANCE
D INSTALLATIONS-, GEBRAUCHS- UND WARTUNGSANLEITUNG
F INSTRUCTIONS POUR L'INSTALLATION, L'EMPLOI ET L'ENTRETIEN
E INSTRUCCIONES PARA LA INSTALACION, USO Y MANTENIMIENTO
SVE BRUKSANVISNINGAR, MONTERINGSINSTRUKTIONER OCH UNDERHÅLLSFÖRESKRIFTER
P INSTRUÇÕES PARA A INSTALAÇÃO, O USO E A MANUTENÇÃO

I CONFEZIONATRICE SOTTOVUOTO
GB VACUUM PACKING MACHINE
D VAKUUMMASCHINE
F MACHINE CONFECTIONNEUSE SOUS-VIDE
E MÁQUINA CONFECCIONADORA
SVE VAKUUMFÖRPACKNINGSMASKIN
P ANTES DE USAR A MÁQUINA LER CUIDADOSAMENTE ESTE MANUAL

MV65



I	Italiano	Pagina 01
GB	English	Page 09
D	Deutsch	Seite 17
F	Français	Page 25
E	Español	Página 33
SVE	Svenska	Sida 41
P	Português	Página 49





DOC. N. FM111077
REV. 0
ED. 12.2008

	Page
Chapter 1. Foreword	
1.1. Preface.....	10
1.2. Performances of packaging machine.....	10
1.3. Technical data of the machine.....	10
Chapter 2. Machine installation	
2.1. Transport and positioning.....	11
2.2. Environmental conditions.....	11
2.3. Users.....	11
2.3.1. Electrical connections.....	11
2.3.2. Gas connections.....	11
Chapter 3. Machine adjustment and setting up	
3.1. Adjustment.....	12
Chapter 4. Limits and conditions in the use of machine	
4.1. Items not to be packed.....	13
Chapter 5. Pouches features	
5.1. Pouches to use.....	13
Chapter 6. Safety standards	
6.1. Warnings.....	14
Chapter 7. Ordinary maintenance	
7.1. Precautions for ordinary maintenance interventions.....	14
7.2. Cleaning of the sealing bar.....	14
7.3. Replacement of the Teflon and the sealing blade.....	14
7.4. Replacement of the cover gasket.....	14
7.5. Cleaning machine.....	15
7.6. Changing the oil and the pump filter.....	15
7.7. Wiring diagram.....	15
7.8. Pneumatic diagram	15
7.9. Disassembling, demolition and elimination of residuals.....	16
Chapter 8. Guarantee	
8.1. Certificate of guarantee.....	16
8.2. Guarantee conditions.....	16
EC declaration of conformity.....	57

1.1. Preface

This manual has been drawn up in compliance with the UNI 10893 standard dated July 2000. It is meant for all users in order to enable them to use the machine correctly. Keep it in a place which can be easily accessed in the proximity of the machine and which is known to all users. This manual is an integral part of the machine for safety reasons. We wish to specify the symbols in use here below in order to improve their understanding.

	ATTENTION: Accident prevention rules for the operator. This warning indicates the presence of dangers which can injure the person operating on the machine.
---	--

	ATTENTION: Hot members. It shows the danger of burning, thus involving the risk of a serious accident for the exposed person.
---	--

	WARNING: It indicates the possibility of damaging the machine and/or its components.
---	---

1.2. Performances of packaging machine

This machine represents what the modern technology of vacuum-packing may express at its best. It is flexible, easily programmable and cheap. It is intended to vacuum-pack foodstuffs by removing oxygen as well as any chemical and biological pollutant present in the environment. To attain the vacuum level you wish, just program the machine in order to remove almost all the air contained in the packet. Your product will preserve its organoleptic features, colour, taste, flavour and nutritive value for a long time.

1.3. Technical data of the machine

Package weight and sizes

- Width = 900 mm
- Length = 985 mm
- Height = 1300 mm
- Weight = 287 Kg (vacuum pump = 60m³)
- Weight = 305 Kg (vacuum pump = 100m³)

Machine weight and sizes (figure 1.3. page 58)

- Width = 820 mm
- Length = 860 mm
- Height with closed cover = 1090 mm
- Height with open cover = 1370 mm
- Weight = 251 Kg (vacuum pump = 60m³)
- Weight = 269 Kg (vacuum pump = 100m³)

Electrical system

- Voltage (V): see data on plate
- Frequency (Hz): see data on plate
- Maximum absorbed power (W): see data on plate
- Maximum absorbed current (A): see data on plate

N.B.: When contacting the Manufacturer, always indicate the model and the serial number specified on the plate on the rear part of the machine.

Vacuum pump = 60m³ / 100m³

I = Electrical connections (figure 1.3. page 58).

H = Gas connection (figure 1.3. page 58).

 MINIPACK® - TORRE S.p.A. 24044 DALMINE (BG) - ITALY w w w . minipack-torre . it			
V	Hz	W max	A max
 MOD _____ FINING _____ MATR _____		MADE IN ITALY	

2.1. Transport and positioning

	<ul style="list-style-type: none"> • When transporting and positioning the machine, it is recommended to handle it with great care! • Neither overturn nor tilt the machine! Oil might come out of the pump and damage the machine.
---	---

		<ul style="list-style-type: none"> • Use protection gloves while handling the machine. • <u>LIFT UP THE PACKING AND MACHINE WITH A FORKLIFT.</u>
---	---	--

Cut the strap (1) with scissors make sure you protect your eyes by wearing glasses and withdraw the cardboard (2). Cut the strap (3) fastening the machine to the pallet (figure 2.1. page 59).

2.2. Environmental conditions

- Lift the machine and place it on the working surface. Make sure the machine is placed in a proper environment without any inflammable and explosive materials or gas. Install on a non-combustible material only.
- Leave a minimal space of 200mm around the machine so that not to obstruct air outlets.
- Once the correct height is obtained, block the machine by means of the wheel brakes.

Working environmental conditions:

- Temperature from + 5°C to + 40°C.
- Relative humidity from 30% to 90%, without condensation.

The lighting of the operation room shall comply with the laws in force in the country where the machine is installed. However, it shall be uniform and provide for good visibility in order to safeguard the operator's safety and health.

MACHINE SAFETY FACTOR = IP20

THE AERIAL NOISE MADE BY THE MACHINE IS LOWER THAN 70 dB

2.3. Users

2.3.1. Electrical connections

	<ul style="list-style-type: none"> • <u>OBSERVE HEALTH AND SAFETY REGULATIONS!</u> • If the machine is not equipped with the power supply plug, use a plug that is suitable for the voltage and amperage values described by the rating plate and that can comply with the rules in force in the installation country. • <u>GROUNDING OF THE UNIT IS OBLIGATORY!</u> (figure 2.3.1. page 59).
---	--

Before executing electrical connections (13), make sure the mains voltage matches the one on the plate (14) on machine rear and that the ground contact complies with the safety rules in force. In case of doubts about the mains voltage, contact the local public supply Company.

2.3.2. Gas connections

Connect gas attachment, in case the machine is equipped with such a device, to the gas cylinder through the proper tube (H) (figure 1.3. page 58). Pressure of gas plant has to be set on about 2 atm., bearing in mind the max. working pressure is 4 atm.

If the pressure is not correct, act on the knob of the pressure reducer (R) (figure 1.3. page 58).

Use specific gas for food package in compliance with the rules in force about food additives in the country where the machine is used.

	<p>Never use gaseous mixtures in presence of oxygen in a percentage higher than the atmospheric one (~ 19%).</p>
---	---

3.1. Adjustment

- 1 Main switch
- 2 Control panel
- 4 Selection button
- 5 Display. Displays selected functions and relative settings
- 6 Button "INCREASE". Increases set function values
- 7 Button "DECREASE". Reduces set function values
- 8 Stop button
- 9 Led for vacuum and extra vacuum function
- 10 Led for gas function
- 11 Led for sealing function
- 12 Led for air re-immission function

(figure 3.1.A page 59).

FEATURES OF THE ELECTRONIC CARD

The machine has 9 selectable programs. Programmes P1÷P8 are composed by 4 modifiable variables. Programme P9 "External Vacuum" is composed by 2 modifiable variables only (Vacuum and Extra-Vacuum). Start it by pressing the Stop button (8).

Variable	Field	Field Features
1) VACUUM	0 ÷ 99,9	Values expressed in %
2) EXTRAVACUUM	0 ÷ 30	Values expressed in seconds
3) GAS	0 ÷ 99	Values expressed in % (never exceed 40%)
4) SEALING	0 ÷ 4	Values expressed in seconds

All packaging machines are tested at works. The parameters set at works generally prove to be fit for use.

PHASE 1 = START-UP

Switch (1) the main switch (1). As soon as the board has been switched on, display will show the software version, then the last program being executed (P1÷P9).

PHASE 2 = PROGRAMS SELECTION

To select the program number, just press the buttons (6) and (7).

PHASE 3 = VARIABLES PROGRAMMING

Press button (4) to enter scheduling of the program shown at the moment. By pressing again button (4), all parameters for the selected program will appear one after the other. Push buttons (6) and (7) to increase or decrease the value of the parameter shown. Parameters are stored when, while running a program, the number of the program itself will appear on the display.

1) VACUUM

It is possible to set a value from 0 to 99,9%.
The recommended vacuum percentage is 99,9%.
Scheduling of vacuum parameter is signalled through LED (9).

2) EXTRAVACUUM

If the vacuum value is set to 99.9%, press button (4) to program the EXTRAVACUUM parameter indicated by the letter E in the last digit on the display.
This value can be set to between 0 and 30 seconds. This is the length of time that the pump continues to extract air from the hood after the machine has reached the programmed maximum vacuum level. This function is useful for porous products where it is particularly difficult to extract the air (e.g. meat).

NB: if the programmed VACUUM value is less than 99.9%, the EXTRAVACUUM function is not displayed, and the system proceeds to the subsequent parameter (GAS).

3) GAS

It is possible to set a value from 0 to 99%. Such a parameter cannot be higher than the vacuum one, otherwise you will obtain an opposite function. Scheduling of gas parameter is signalled through LED (10). If the gas LED (10) is flashing, it means the gas cylinder is not properly connected and machine will not start. Connect it properly.

N.B.: When scheduling a program "vac + gas", the minimum residual vacuum percentage soon after gas immission should be higher than 60%.

Example: VAC 99,9%
GAS 40%
Residual vacuum (99,9 - 40)= 59,9%

4) SEALING

It is possible to set a value from 0 to 4 seconds. For the first working cycles it is recommendable to set a sealing time of about 2,5 seconds and then lower it to prevent the teflon tape from burning. Scheduling of sealing time parameter is adjusted through LED (11).

3.1. Adjustment**PHASE 4 = EXECUTION**

Arrange the maximum number of shelves (13) the hood (14) may accommodate according to the sizes of the product to be packed.

Place the envelope inside the hood and on the sealing bar in a way as linear as possible. Try to prevent the envelope from wrinkling. Wrinkles might negatively affect the hermetic seal formed by sealing. Envelopes shall be at least 2 cm beyond the sealing bar (figure 3.1.B page 59).

If the "GAS" function is on, the envelope must be positioned with the strip open on the gas nozzle on one side of the sealing bar.

Lower the upper plexiglas cover.

The packaging cycle will start. It consists of 4 phases (figure 3.1.C page 59):

1. Suction phase during which all the air contained inside the bell and the bag is sucked.
2. Gas injection phase (if the machine is equipped with a gas plant).
3. Sealing phase during which the packet is sealed.
4. Air re-enter phase and subsequent opening of the cover.

The hood will reach its atmospheric pressure and the upper cover will open again.

Machine is ready for a new packing cycle.

After every working cycle, on the display will appear a number showing the total cycles being executed.

All set-up parameters are stored until they are modified.

N.B.: if you press the **Stop** button (8), the machine will immediately stop sucking and automatically start sealing the pouch. This function will be used to pack liquid and hot products which may start boiling during the vacuum cycle.

ELECTRONIC BOARD FUNCTIONS

OIL: When you read OIL on the display, do check oil level and colour like mentioned at chapter 7.6.

Set to 0 the function pressing buttons (6) and (7) at the same time.

OFF: When you read OFF on the display, it means that card is shutdown.

Do get in contact with the assistance service.

4.1. Items not to be packed

It is absolutely forbidden to pack the following products which might permanently damage the machine and harm operator:



- Liquids of any type and density in fragile containers
- Inflammable and explosive materials
- Gas bottles under pressure or of any type
- Bulk or volatile powders (unless a filter is assembled on the pump)
- Any material and product which might in any way cause the user to be in a dangerous situation and damage the machine.





5.1. Pouches to use

They may be of different thickness and shall be both airtight and gastight.





It is recommended to refer to the technical and safety sheets of the pouches in use and to observe the corresponding instructions!

6.1. Warnings**THE MACHINE CAN NOT BE USED BY UNTRAINED PERSONNEL!**

	<p>Do not touch the sealing blade (16) immediately after sealing (figure 6.1.A page 60). Danger of burns due to hot blade.</p> <p>Do not touch the vacuum pump (23) just after a working cycle (figure 6.1.B page 60). Possibility of burning due to the high temperature the pump may reach.</p> <p>USE PROTECTION GLOVES!</p>
	<p>Do not seal if the sealing wire is broken. Replace it immediately.</p> <p>In case of a power failure during a working cycle when the cover is closed, do not use any tool in order to force its opening. Wait for the power supply to be restored (figure 6.1.C page 60).</p>
	<p>Before any working cycle make sure that the closing hook (19) will not prevent the operator from closing the cover correctly (figure 6.1.D page 60). Possibility of breaking the cover.</p>
	<p>Never use gaseous mixtures in presence of oxygen in a percentage higher than the atmospheric one (~ 19%).</p>

Chapter 7. Ordinary maintenance**7.1. Precautions for ordinary maintenance interventions****ORDINARY MAINTENANCE, MUST BE EXECUTED BY QUALIFIED STAFF APPROPRIATELY TRAINED.**

	<p>Before any routine maintenance switch the machine off by acting on the main switch and remove the plug from the mains socket. Disconnect gas plant.</p>
	<p>It is recommended to use protection gloves during maintenance operations!</p>

7.2. Cleaning of the sealing bar

Use a dry cloth to remove any film residue on the sealing bar (16). Carry out this operation just after any sealing cycle. Residues are still hot and may be easily removed (figure 7.2. page 60).

7.3. Replacement of the Teflon and the sealing blade

Before replacing teflon and the sealing blade wait for the machine to be properly cooled.

- Remove the sealing bar (16) from its seat (figure 7.3.A-7.3.B page 60)
- Remove the teflon adhesive tape
- Unscrew the nuts fastening the blades to each end of the sealing bar
- Tighten the new blades. Make sure they are tout enough before blocking them
- Use the teflon adhesive tape to cover the sealing blades
- Place the sealing bar into its seat.

7.4. Replacement of the cover gasket

When the cover gasket (17) is worn out, replace it (figure 7.4. page 61).

This will improve the efficiency of the machine and increase its speed rate. Replacement is very easy. After having removed the gasket which has worn out, clean its seat and insert the new gasket in a linear way. Make sure its ends are joined. Leave no opening which might prevent the product from being properly vacuum-packed.

7.5. Cleaning machine



**To clean the plexiglas cover (18), clean both the outer and the inner side with water and soap only (figure 7.5. page 61).
Never use detergents or solvents which might damage the cover (18) and reduce its transparency as well as its resistance.**

Use normal detergents for stainless steel to clean the case and the internal tank.

7.6. Changing the oil and the pump filter

Follow the instructions you can find on the pump manual in order to change the oil and the vacuum pump filter. However, oils of the VG type shall be used in compliance with the DIN 51506 standards.



The oil you have replaced must be eliminated according to the procedures established by the laws in force in the country the equipment has been installed.

(20) **PLUG FOR OIL DISCHARGE** (to completely replace old oil)

(21) **OIL FILLING PLUG**

(22) **VISUAL LEVEL**

(figure 7.6. page 61).

7.7. Wiring diagram

208V ETL / 220V / 380V 3Ph (figure 7.7. page 62).

- Q1 Main switch
- F1 Blade fuse 10.3X38
- F2 Auxiliary transformer fuse 10.3X38
- FU1 Board fuse 5X20
- QM1 Motor contactor
- QM2 Blade heater contactor
- QV1 Air re-immission valve
- QV2 Gas injection airvalve
- QV3 Sealing airvalve
- QV4 Elettrovalvola vuoto
- M1 Vacuum pump motor
- T1 Blade transformer
- T3 Blade transformer
- T2 Auxiliary transformer
- ER1 Blade heater
- ER2 Blade heater
- B0 Limit switch
- B1 Gas pressure switch
- SK1 Control board
- QF1 Automatic switch

220V ETL 1Ph (figure 7.7. page 63).

- Q1 Main switch
- F1 Blade fuse 10.3X38
- F2 Auxiliary transformer fuse 10.3X38
- FU1 Board fuse 5X20
- QM1 Motor contactor
- QM2 Blade heater contactor
- QV1 Air re-immission valve
- QV2 Gas injection airvalve
- QV3 Sealing airvalve
- QV4 Elettrovalvola vuoto
- M1 Vacuum pump motor
- T1 Blade transformer
- T3 Blade transformer
- T2 Auxiliary transformer
- ER1 Blade heater
- ER2 Blade heater
- B0 Limit switch
- B1 Gas pressure switch
- SK1 Control board
- QF1 Automatic switch
- C1 Vacuum pump condenser

7.8. Pneumatic diagram

(figure 7.8. page 64).

- CV Vacuum hood
- UG Gas nozzles
- BA Suction pipe union
- QV1 Air re-immission valve
- QV2 Gas injection airvalve
- QV3 Sealing airvalve
- QV4 Vacuum airvalve
- B1 Gas pressure switch
- BG Gas cylinder
- MP Pneumatic membrane
- M1 Vacuum pump motor
- PV Vacuum pump
- S Sensor

7.9. Disassembling, demolition and elimination of residuals**ATTENTION!**

All operations about disassembling and demolition must be done by qualified personnel with mechanical and electrical expertise required to work in security conditions.

Proceed as follows:

1. disconnect machine from power mains
2. disassemble components
3. remove oil from the pump.

All wastes must be treated, eliminated or recycled according to their classification and to the procedures in force established by the laws in force in the country the equipment has been installed.



The symbol indicates that this product shall **not** be treated as household waste.

By assuring that the product will be properly disposed of, you will facilitate the prevention of potential negative effects for the environment and the man's health, which might be otherwise caused by the improper waste treatment of this product.

For more detailed information about the recycling of this product, please contact the product seller or, as an alternative, the after-sales service or the corresponding waste treatment service.

Chapter 8. Guarantee**8.1. Certificate of guarantee**

The guarantee runs for 12 months after the installation date under the conditions set forth on the instruction manual.

Fill in the card with all data requested tear out along the perforations and send in.

8.2. Guarantee conditions

The guarantee runs for 12 months and goes into force on the installation date of the machine. The guarantee covers free replacement or repair of any parts due to defects arising from faulty material. The repairs or replacement are usually carried out at the manufacturer's, with transport or workmanship at buyer's charge. If the repair or replacement is carried out at the buyer's place, he shall bear the travelling, transfer and workmanship charges. Work under guarantee can be carried out exclusively by the manufacturer or by the authorised dealer. In order to be entitled to repairs under the guarantee, the faulty part must be sent for repair or replacement to the manufacturer or his authorised dealer. The return of such repaired or replaced part will be considered to be the performance of the guarantee.

The guarantee is voided:

1. in case of failure to mail the CERTIFICATE OF GUARANTEE, duly filled in and signed, within 20 days after the date of purchase.
2. in case of inappropriate installation, power supply, misuse and mishandling by unauthorised persons.
3. in case of changes made to the machine without prior agreement in writing by the manufacturer.
4. if the machine is no longer the property of the first buyer.

The manufacturers decline any responsibility for damage to persons or things in case of inappropriate installation or connection to the power mains or omission of connection to earth or in case of any mishandling of the machine. The manufacturers undertake to carry out any variations and changes made necessary by technical and operating requirements.



I DICHIARAZIONE CE DI CONFORMITA'
GB EC DECLARATION OF CONFORMITY
D EG KONFORMITÄTSEKTLÄRUNG
F DECLARATION CE DE CONFORMITE'
E DECLARACION CE DE CONFORMIDAD
SVE ÖVERENSTÄMMELSEFÖRKLARING EC
P DECLARAÇÃO CE DE CONFORMIDADE
GR ΔΗΛΩΣΗ ΠΙΣΤΟΠΟΙΗΣΗΣ CE

I Noi:
GB We:
D Wir:
F Nous:
E Nosotros:
SVE Vi:
P Nós:
GR Εμείς:

MINIPACK-TORRE S.p.A.
Via Provinciale, 54
24044 DALMINE (BG)

I dichiariamo sotto la nostra esclusiva responsabilità che il prodotto
GB declare under our responsibility that the product
D erklären unter unserer ausschließlichen Verantwortung daß, das in dieser Erklärung genannte Produkt
F déclarions sous notre exclusive responsabilité que le produit
E declaramos bado la nuestra esclusiva responsabilidad que el producto
SVE förklarar under eget ansvar, att produkten
P declaramos sob a nossa exclusiva responsabilidade que o produto
GR δηλώνουμε υπό δική μας αποκλειστική ευθύνη ότι το προϊόν

I macchina confezionatrice tipo:
GB packing machine model:
D Verpackungsmaschine Typ:
F machine confectionneuse modèle:
E maquina confeccionadora tipo:
SVE packningsmaskin typ:
P máquina confeccionadora tipo:
GR μηχανή συσκευασίας τύπου:

MV65

n°

I è conforme a quanto prescritto dalle seguenti direttive e successive modifiche:
GB is in conformity with provision of following directives and their modifications:
D ist im vebereinstimmung mit den Sicherheitszielen der Bestimmungen und Zuckünftige warianten:
F est en conformité avec les normatives prevues par les suivantes directives et successifs modifications:
E es conforme a cuanto previsto de la directiva y sucesivas modificaciones:
SVE är överensstämmande med föreskrifterna i följande direktiv och dess därpå följande ändringar:
P está em conformidade com quanto prescrito nas seguintes directivas e modificações sucessivas:
GR είναι σύμφωνο με όσα προβλέπουν οι ακόλουθες οδηγίες και ακόλουθες τροποποιήσεις:

98/37/CE
2004/108/CE
2006/95/CE

I E inoltre dichiariamo che sono state applicate le seguenti norme armonizzate:
GB And furthermore we declare that the following rules have been applied:
D Und ausserden, wir bestaetigen dass, die folgenden bestimmungen angewandt sind:
F Et de plus nous declaron que les normes suivantes ont été appliques:
E Y además declaramos que han sido aplicadas las siguientes normas armonizadas:
SVE Dessutom förklarar vi, att följande harmoniserade normer har använts:
P E, além disso, declaramos que foram aplicadas as seguintes normas harmonizadas:
GR Επίσης δηλώνουμε ότι εφαρμόστηκαν οι εξής τροποποιημένοι κανόνες:

EN 12100-1
EN 12100-2
EN 60335-1
EN 60204-1

Dalmine,

TORRE ing. FRANCESCO

I Consigliere delegato **E** Consedero Delegato
GB Managing Director **SVE** Verkställande Direktör
D Geschäftsführer **P** Conselheiro Delegado
F Conseiller Délégué **GR** Ο Διευθύνων Σύμβουλος

1.3.

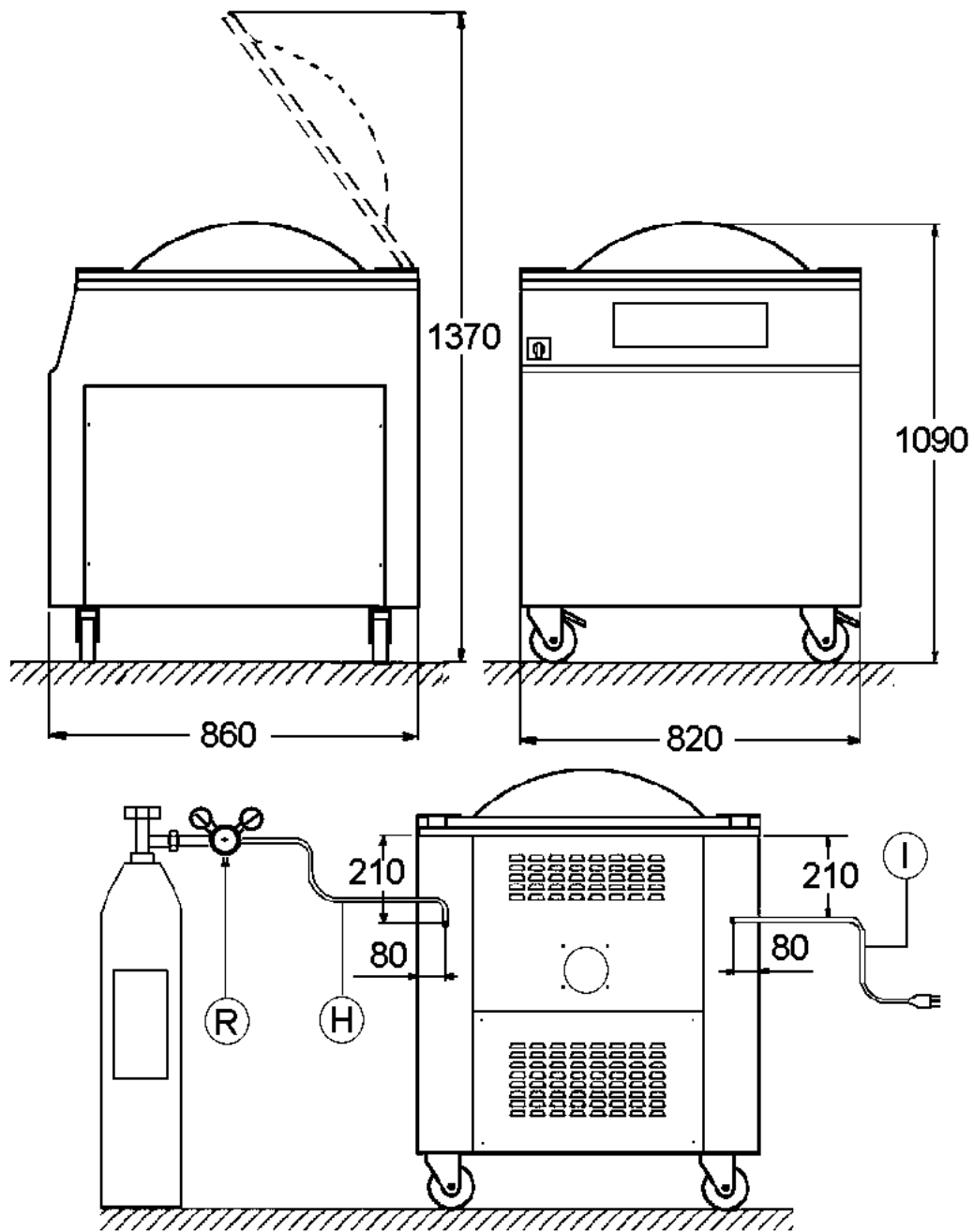

2.1.

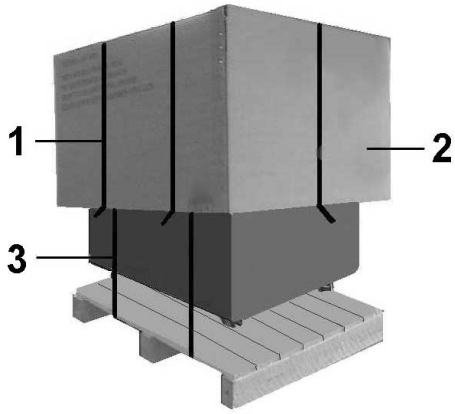

2.3.1.

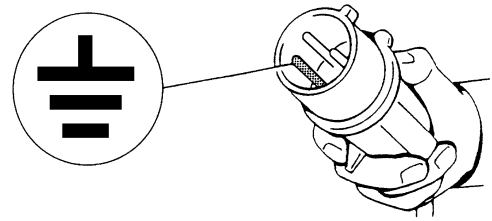

3.1.A

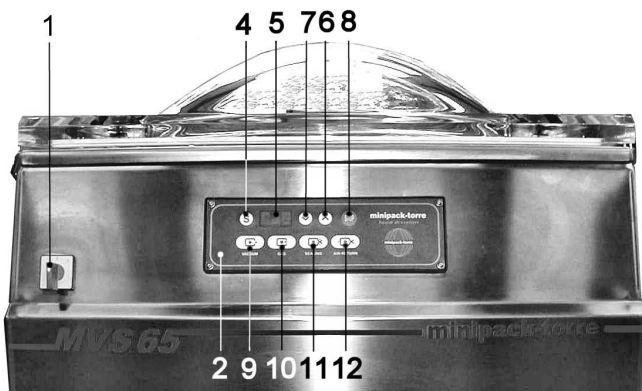

3.1.B



3.1.C

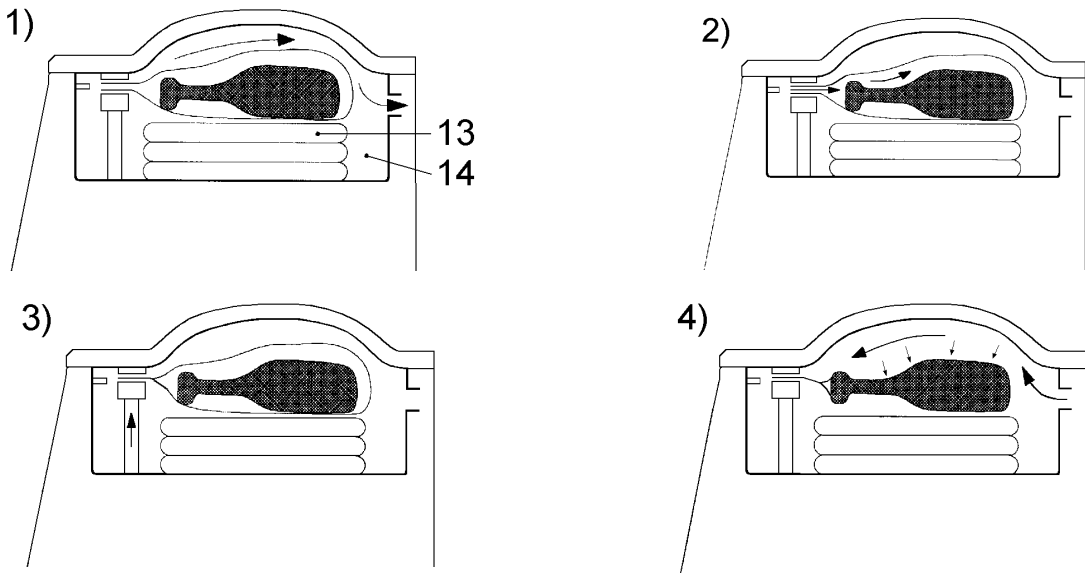

6.1.A.

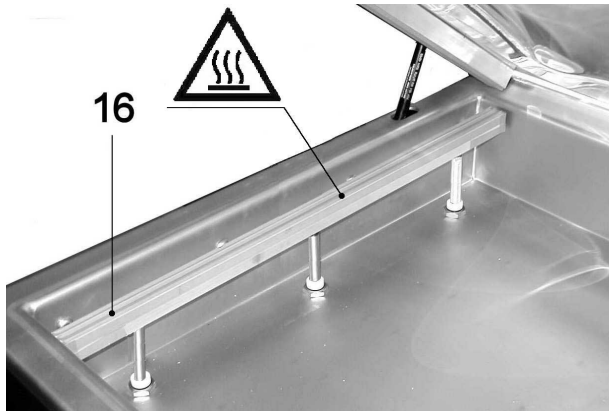

6.1.B

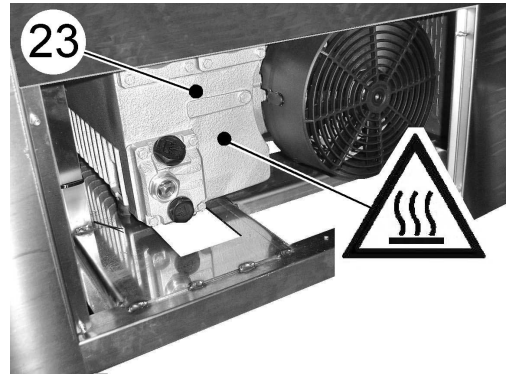

6.1.C

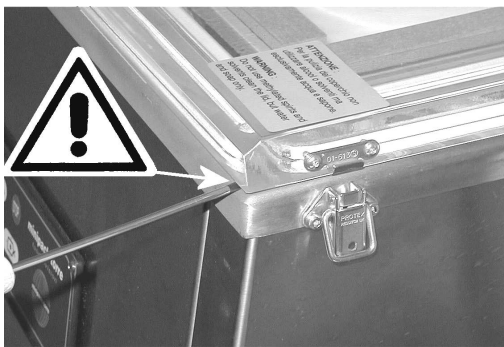

6.1.D

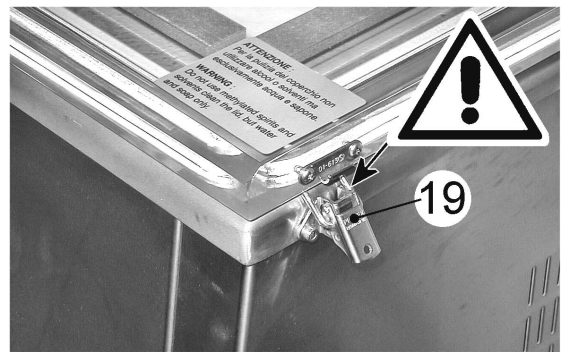

7.2.

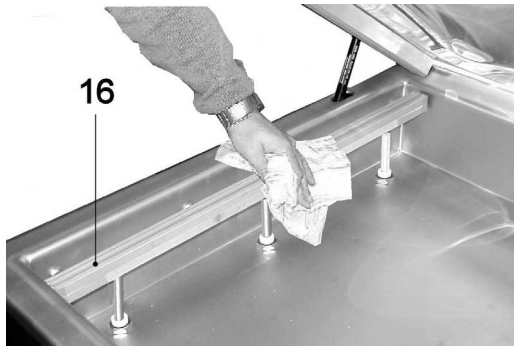

7.3.A

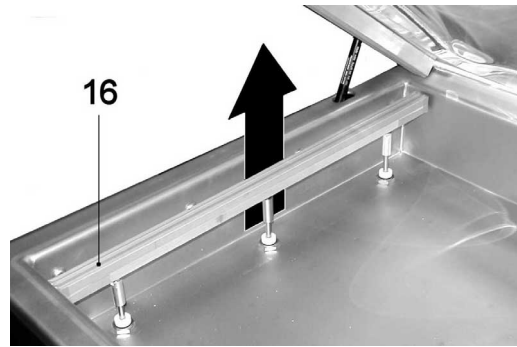

7.3.B

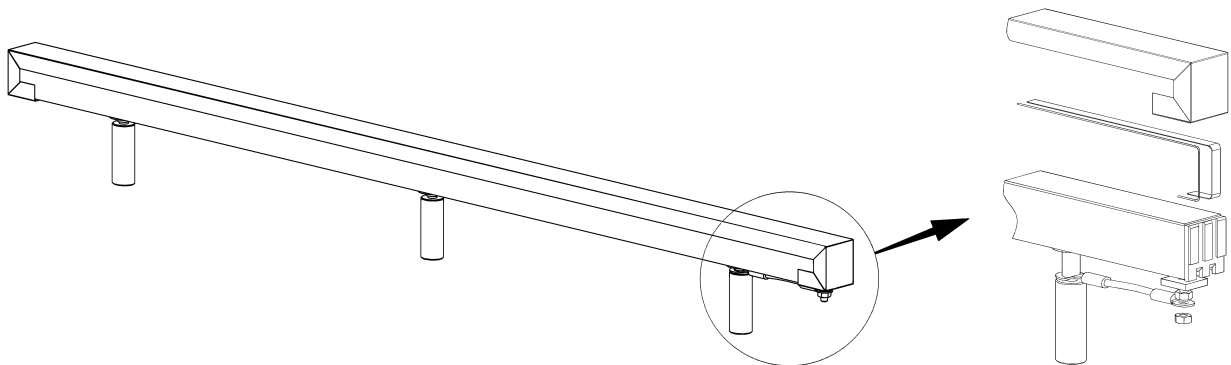

7.4.



7.5.

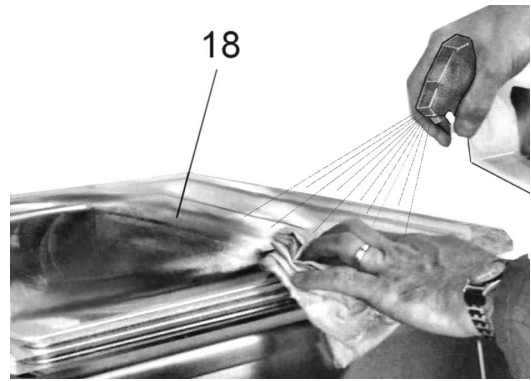

7.6.

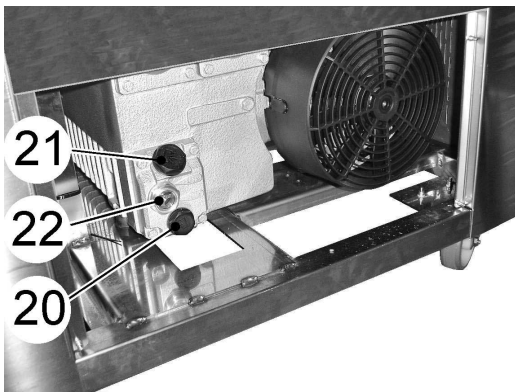

7.7. (versione 208V ETL - 220V - 380V 3Ph / 208V ETL - 220V - 380V 3Ph version)

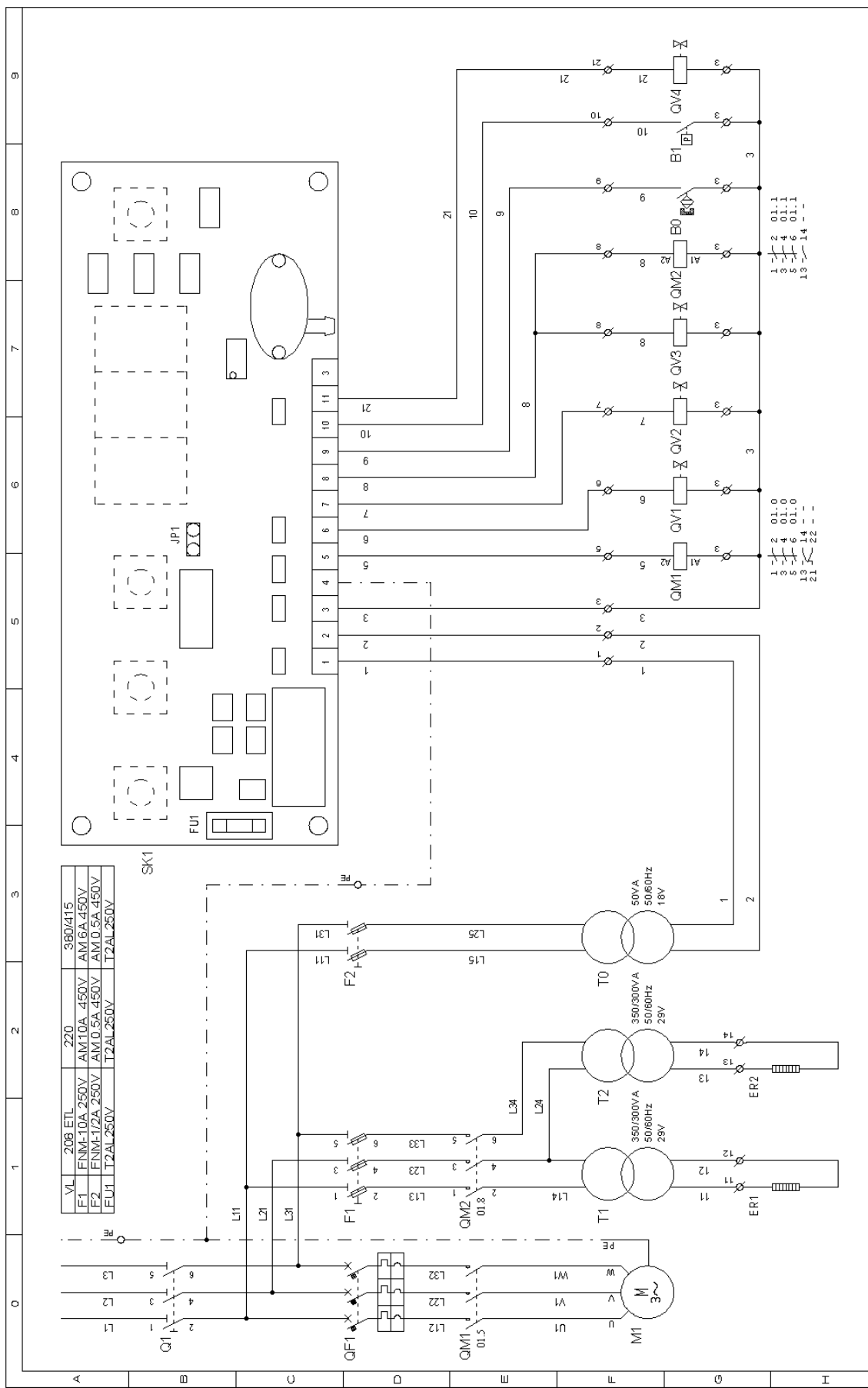

VL	208 ETL	220	9804115
F1	FN1M-10A 250V	AM10A 450V	AM16A 450V
F2	FN1M-172A 250V	AM10.5A 450V	AM10.5A 450V
FU1	T2AL 250V	T2AL 250V	T2AL 250V

PROGETTO:	MV66 TRIFASE	FOGLIO	01
CODICE:		DI	01
DESIGNO NR:	WDMV6501		
TITOLO:	SCHEMA DI POTENZA / COMANDO		
DESIGNATORE:	Boldoni	DATA:	12.10.2004
REV.	DATA	FIRMA	MODIFICA

7.7. (versione 220V ETL 1Ph / 220V ETL 1Ph version)

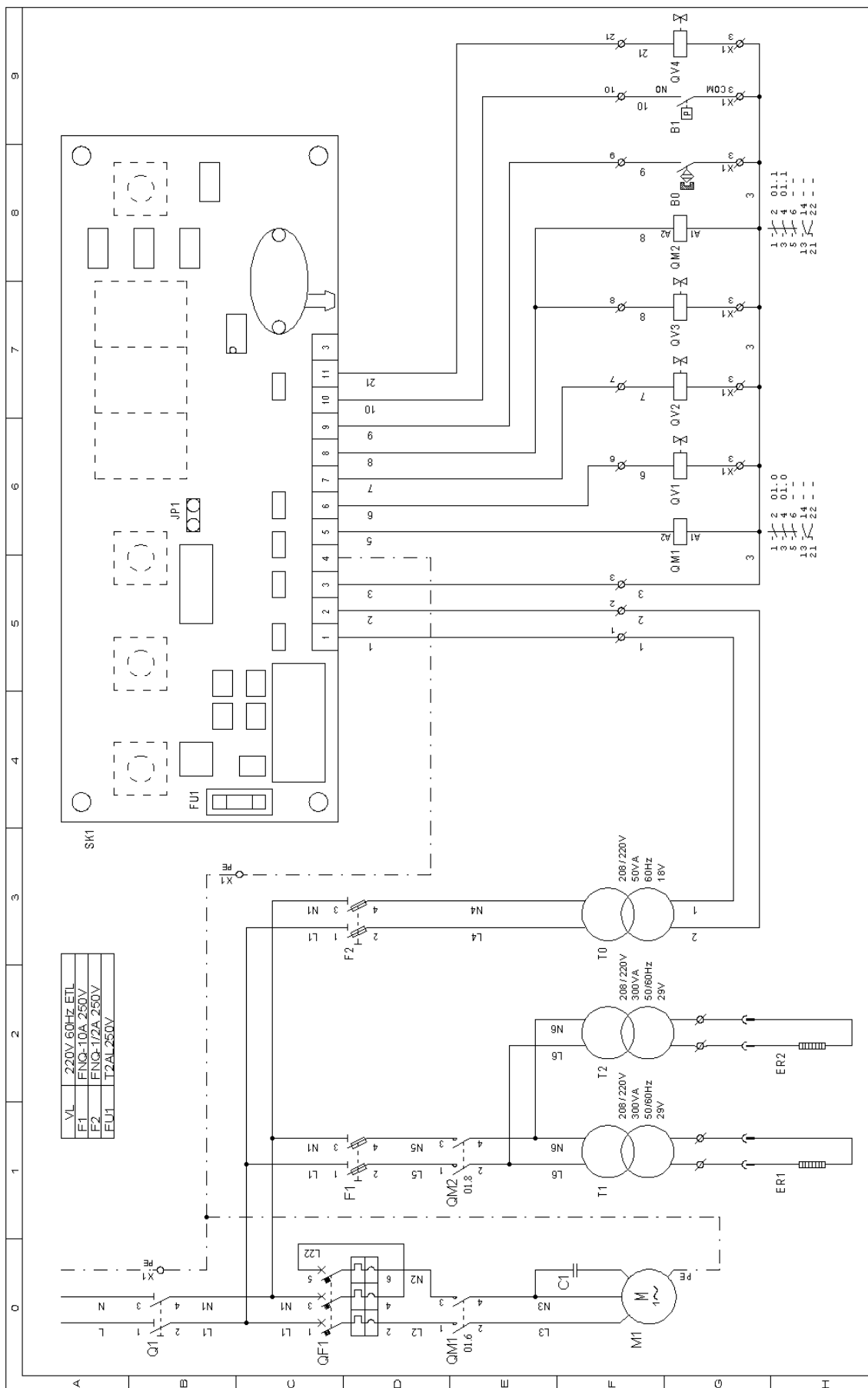

PROGETTO:	MY65 MONOFASE ETL	FOGLIO	01
CODICE:		DI	01
DISGNO NR:	WDMY6502	TITOLO:	SCHEMA DI POTENZA / COMANDO
DISSEGNAZIONE:	Boldart	DATA:	06/06/2007

7.8.

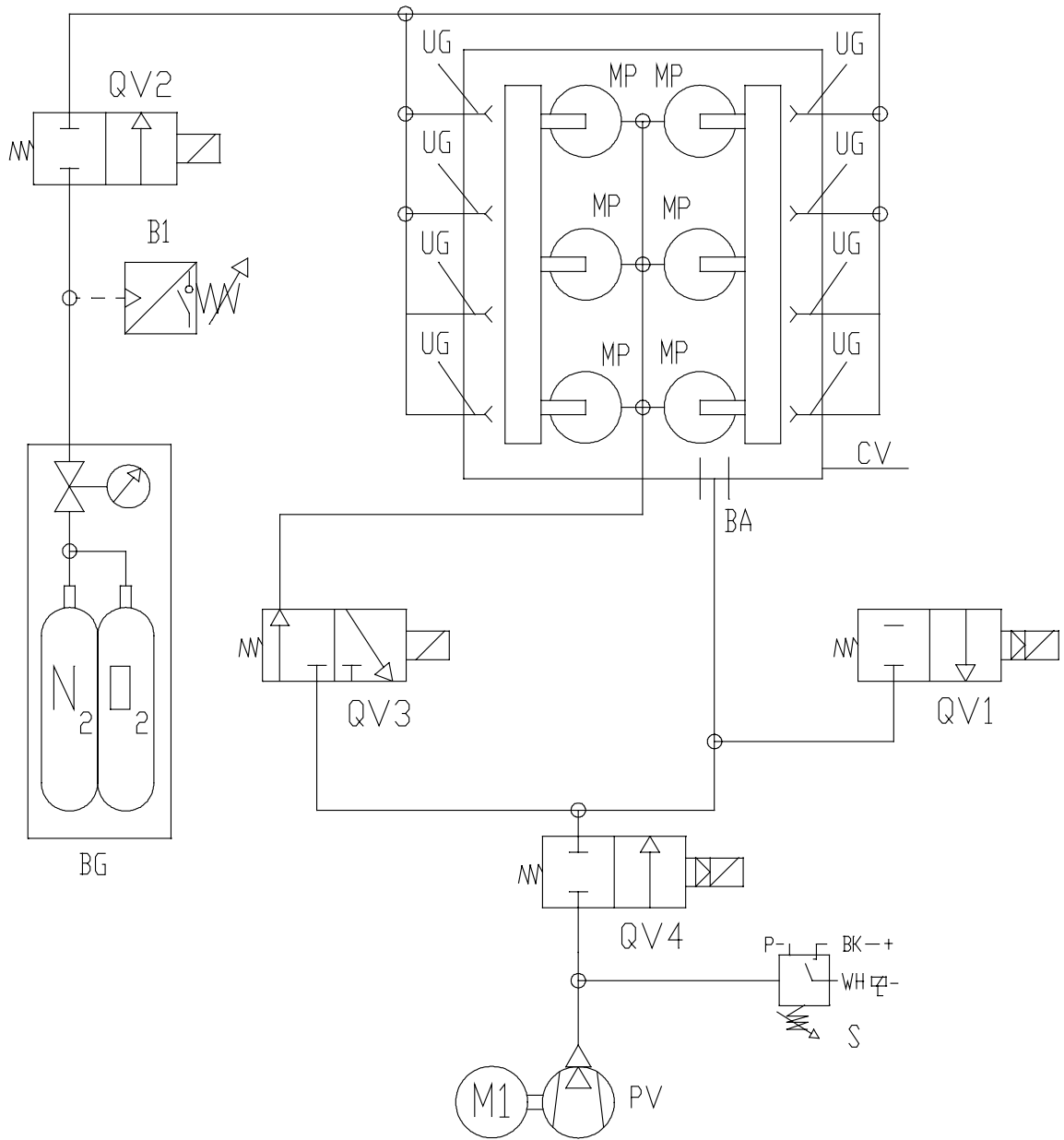

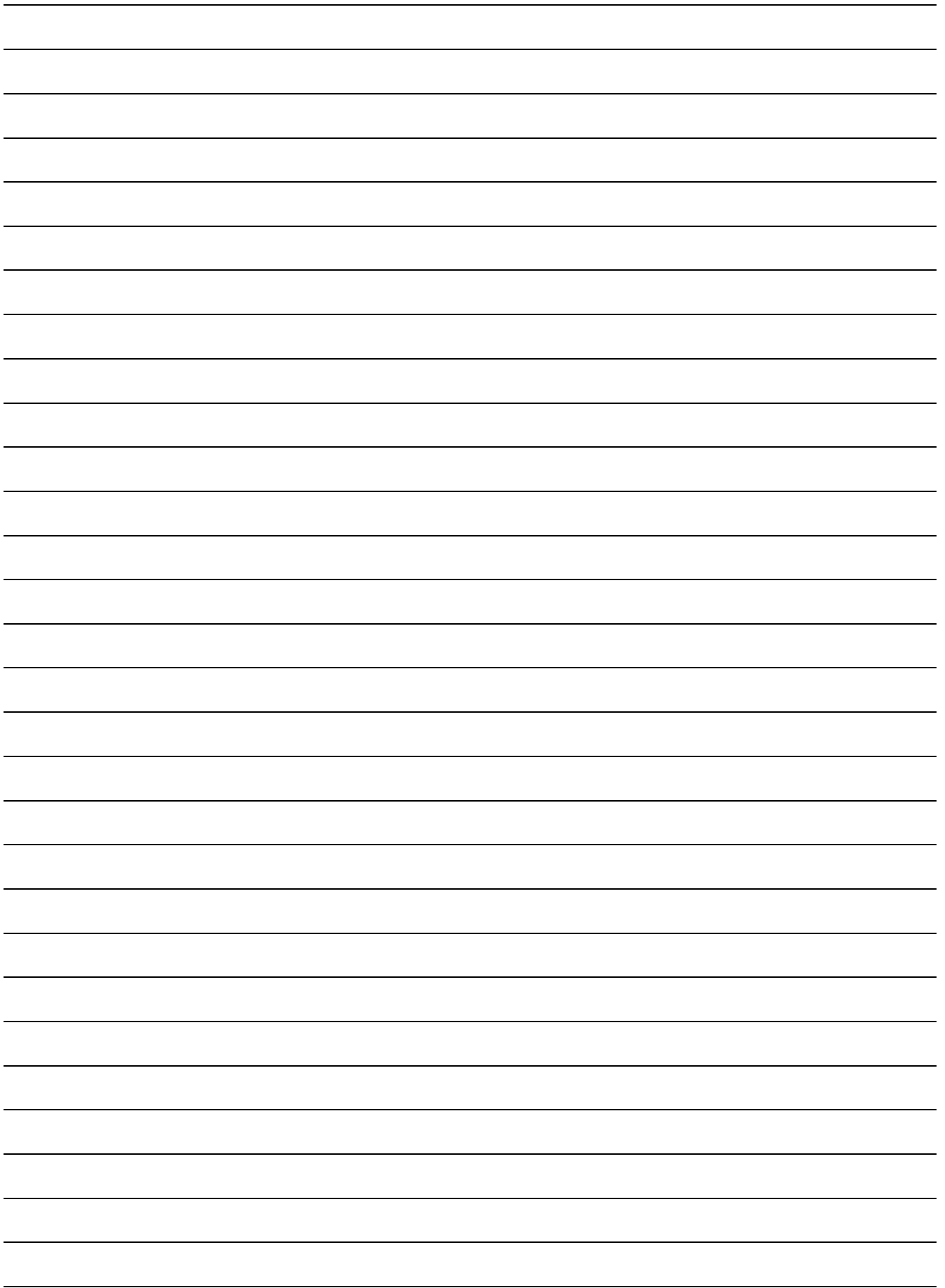

(I) Tipo
(GB) Type
(D) Typ
(F) Type
(E) Tipo
(SVE) Typ
(P) Tipo

(I) Matricola
(GB) Serial n°
(D) Kennnummer
(F) No. de série
(E) No. de matrícula
(SVE) Registreringsnummer
(P) Número de série

(I) Collaudo
(GB) Test n°
(D) Abnahmeprüfung
(F) Essai
(E) Ensayo
(SVE) Besiktning
(P) Teste

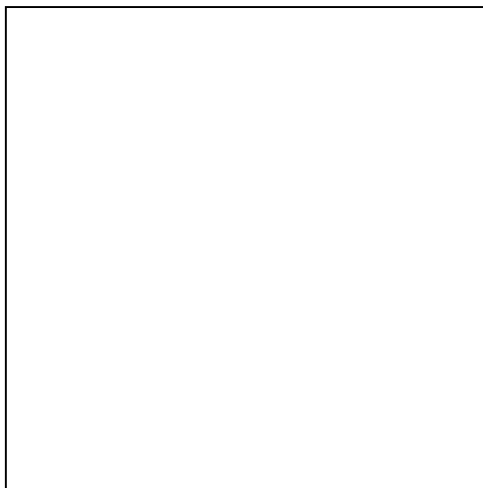

CERTIFICATO DI GARANZIA
CERTIFICATE OF GUARANTEE
GARANTIESCHEIN
BULLETIN DE GARANTIE
CERTIFICADO DE GARANTIA
GARANTIINTYG
CERTIFICADO DE GARANTIA

Data e timbro rivenditore
Date and dealer's stamp
Datum und stempel des verkaufers
Date et timbre du revendeur
Fecha y timbre del revendedor
Datum och återförsäljarens stämpel
Data e carimbo revendedor

(I) Indirizzo acquirente
(GB) Customer address
(D) Adresse des Abnehmers
(F) Adresse de l'acheteur
(E) Dirección del comprador
(SVE) Köparens adress
(P) Endereço comprador

(I) Data di acquisto
(GB) Date of purchase
(D) Einkaufdatum
(F) Date d'achat
(E) Fecha de compra
(SVE) Inköpsdatum
(P) Data de compra

.....
.....
.....
.....
.....

.....

Minipack-torre S.p.A.

Via Provinciale, 54 - 24044 DALMINE (BG) - ITALY

Tel. (035) 563525 – Fax (035) 564945

E-mail: info@minipack-torre.it

<http://www.minipack-torre.it>



Spett.le

Minipack-torre S.p.A.

Via Provinciale, 54
24044 DALMINE (BG)
ITALY

MADE IN ITALY